

ELEM.	DESCRIZIONE	QT	NUMERO PARTE	REV	ASPETTO SUPERF.
9	GR.BRACCIOVERT.EVOLVO CON CINGHIA H=2900	1	C1CG0100	0	NO
8	GRUPPO BRACCIO FISSO EVOLVO III	1	C1CG0094	0	NO
7	PULEGGIA HTD 18 5M 25 M8 LAV. A DISEGNO	1	C1HA0128	0	NO
6	GRUPPO PROTEZIONE INF EVOLVO POLICARB	1	C1CG0043-PC	0	No
5	GRUPPO BRACCIO ROTANTE CON PIASTRA	1	C1CG0020	3	NO
4	PIEDISTALLO MONOBRACCIO	1	C1CG0008	1	NO
3	GRUPPO CARRELLO PPS BRACCIO	1	C1-C1CG0101	0	NO
2	CASSETTA ELETTRICA PORTASCHEDA C-ONE	1	C1BG0071	5	NO
1	WT34-B410	1	SIK1019229	0	NO
Elenco componenti					

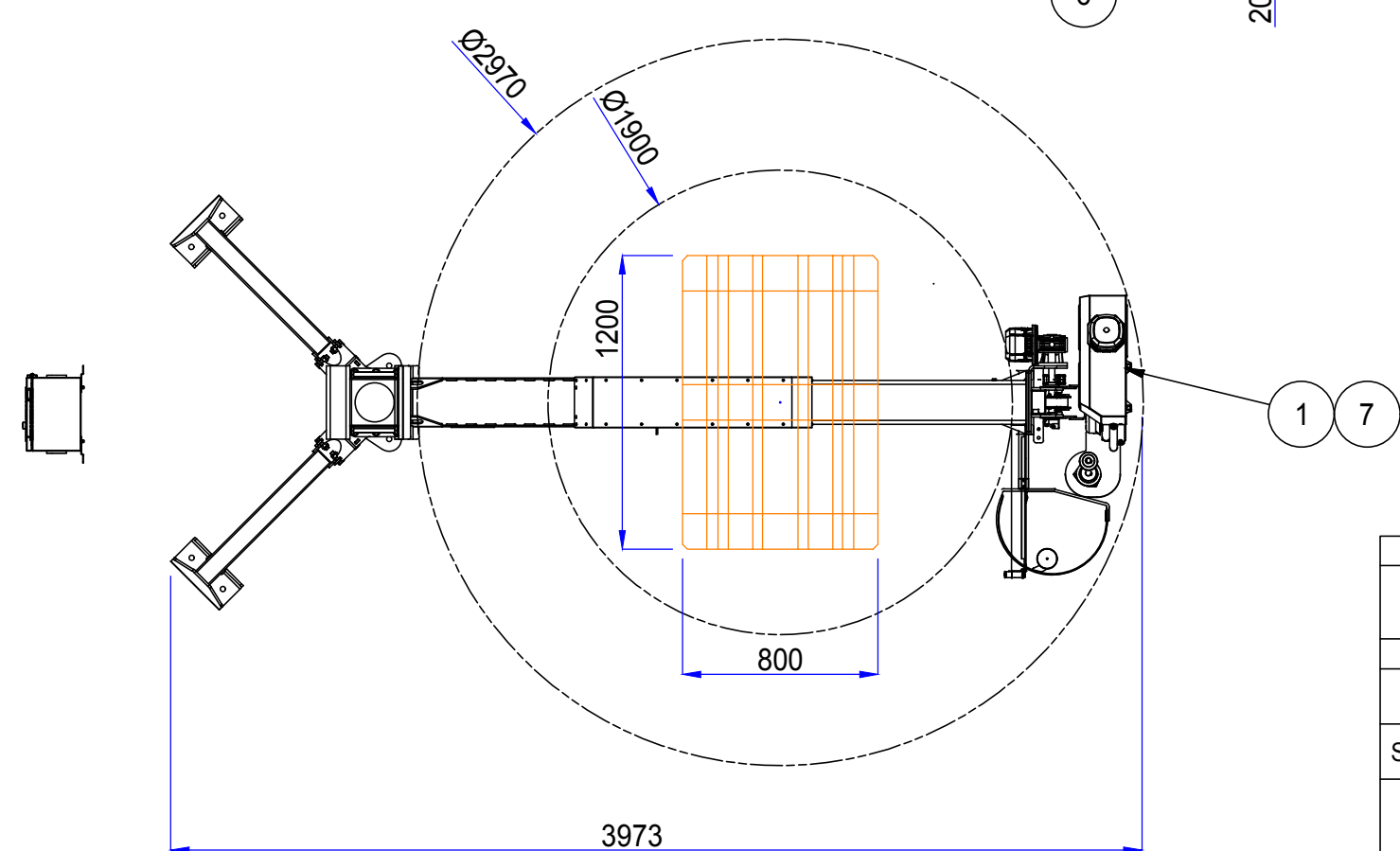
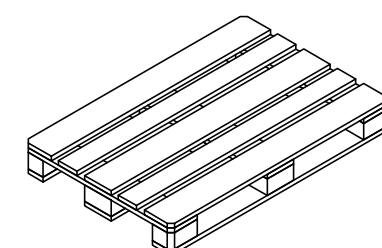

CONFIRM

DATE

SIGN

DESCRIPTION				
EVOLVO Ø1900 PALLET 800x1200 H2400				
DESIGNER		CLIENT		WEIGHT
DATE	11/10/2021	END CUSTOMER		SCALE
SIGNED	Cappelli M	705 kg	1 :30	
N° DIS.			REVISIONE	
			0	